

Description

KTC.900 is a product designed for 8-12 ton capacity medium duty 4x4 rubber-tired vehicles. The product is mounted between the shafts in the middle of front-rear differential. There are 2 ratios available: high-low. There is also a neutral gear to let the vehicle's shaft rotate freely in case of emergency. The transfer case transfers the rotation from the transmission to the rear and front differential with ratios. A differential lock feature has been added to control the drive in the front wheel. The gearbox can be directly coupled with Allison 1000-2000 series transmissions.

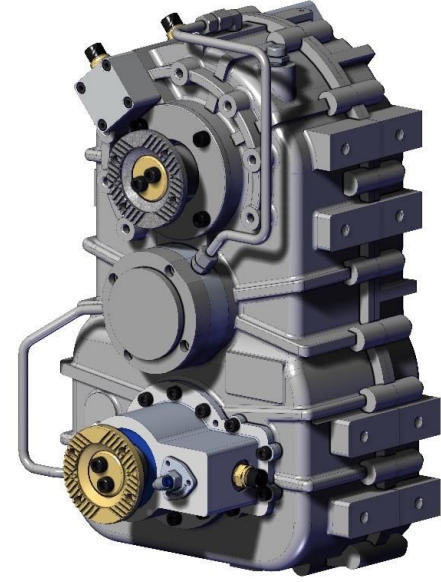

Technical Specification

Main Drive

Maximum continuous torque (Nm)	6000 Nm
Maximum instantaneous torque (Nm)	5800 Nm
Maximum Speed (rpm)	5300 rpm

Differential Output

Maximum torque available at shaft (Nm)	9000 Nm
Maximum Speed (rpm)	5830 rpm
High Drive Ratios	1.10
Low Drive Ratios	0.56
Oil Capacity (Vertical Assembly)	8.5 Lt

Kozmaksan KTC.900



Available Options

Options	Aplication
1-Rpm Counter 2-High Mode Control Sensor 3-Neutral Gear Control Sensor 4-Low Mode Control Sensor 5-4x2-4x4 Control Sensor	1-Military Vehicles

Dimensions

